

TMR MIXER

M30S

M30S

THE «PLUG & MIX» MIXER



DESCRIPTION

A «**Plug&Play**» conception.
A single unit, all-in and ready to use!



Optional

- Compact, efficient and energy-saving
- Made of Canadian steel 44W
- Tub covered with a **stainless steel liner** of 30" (76 cm)
- A **Hardox** auger
- A **Direct Drive** motor
- A **Heavy Duty** planetary
- An **enclosed** and lubrication free PTO
- An optional 2-years or 5-years warranty period, parts and labour

A multifunction mixer: straw, reserve, TMR...
More performances, less maintenance!

DETAILS

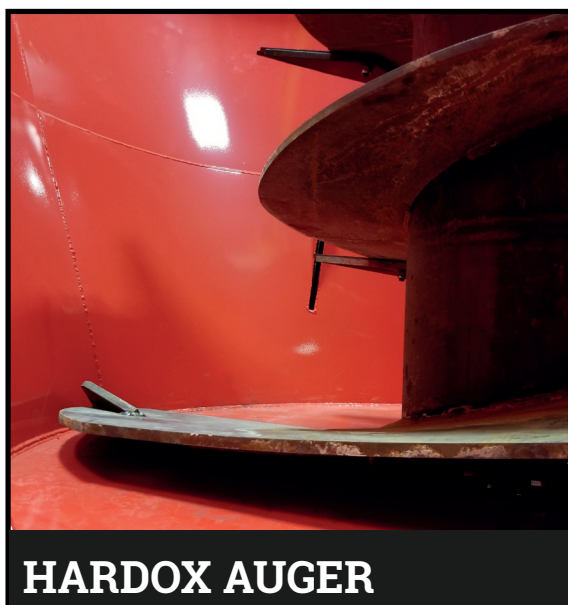

HARDOX AUGER

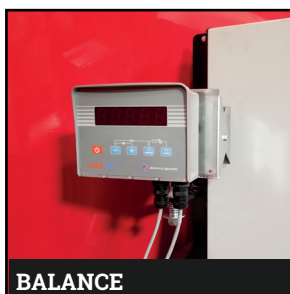

BALANCE



ELECTRIC CYLINDER



MANUAL CONTROL PANEL

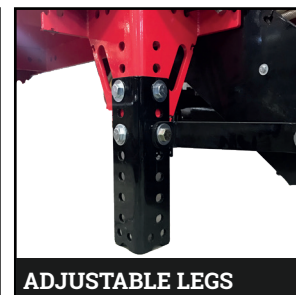

ADJUSTABLE LEGS

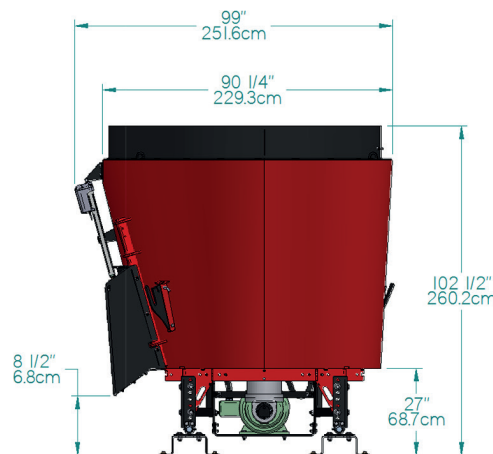
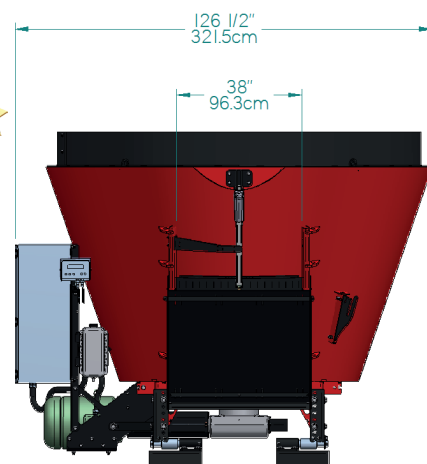

TECHNICAL SPECIFICATIONS

CAPACITY	From 235 pi ³ (6.7m ³) to 278pi ³ (7.9m ³) with 10" (25.4 cm) rubber extension
RUBBER EXTENSION	A 10" (25.4 cm) extension is available as an option Included in the 30HP motorization option
MOTORIZATION	High efficiency Direct Drive motor with variable speed 20 HP as standard, 30HP as an option Left, right or back motorization
CONTROL PANEL AND DRIVE	Manual panel 20 HP or 30 HP Drive control up to 4 speeds motor for auger rotation
PLANETARY	Heavy Duty planetary
PTO	Enclosed PTO, lubrication free
BALANCE AND LOADCELLS	DINAMICA or DIGISTAR balance and 4 loadcells, up to 10 000Lbs (4535 Kg)
DISCHARGE DOOR	The discharge door is controlled by an electric cylinder 1500 Lbs (680 Kg) torque with Amp management
KNIVES	4 knives and 4 strongbacks included
STEEL	Canadian steel 44W, 1/2" (12mm) thick for the floor and 1/4" (6mm) for the walls Hardox auger
DIMENSIONS (L X l X H) WITHOUT EXTENSION	126" 1/2 X 99" X 95" (321.5 cm X 260.2 cm X 241.3 cm)
WEIGHT	5500 Lbs (2495 Kg)