

MIXER

MX

MX

PADDLE
MIXER

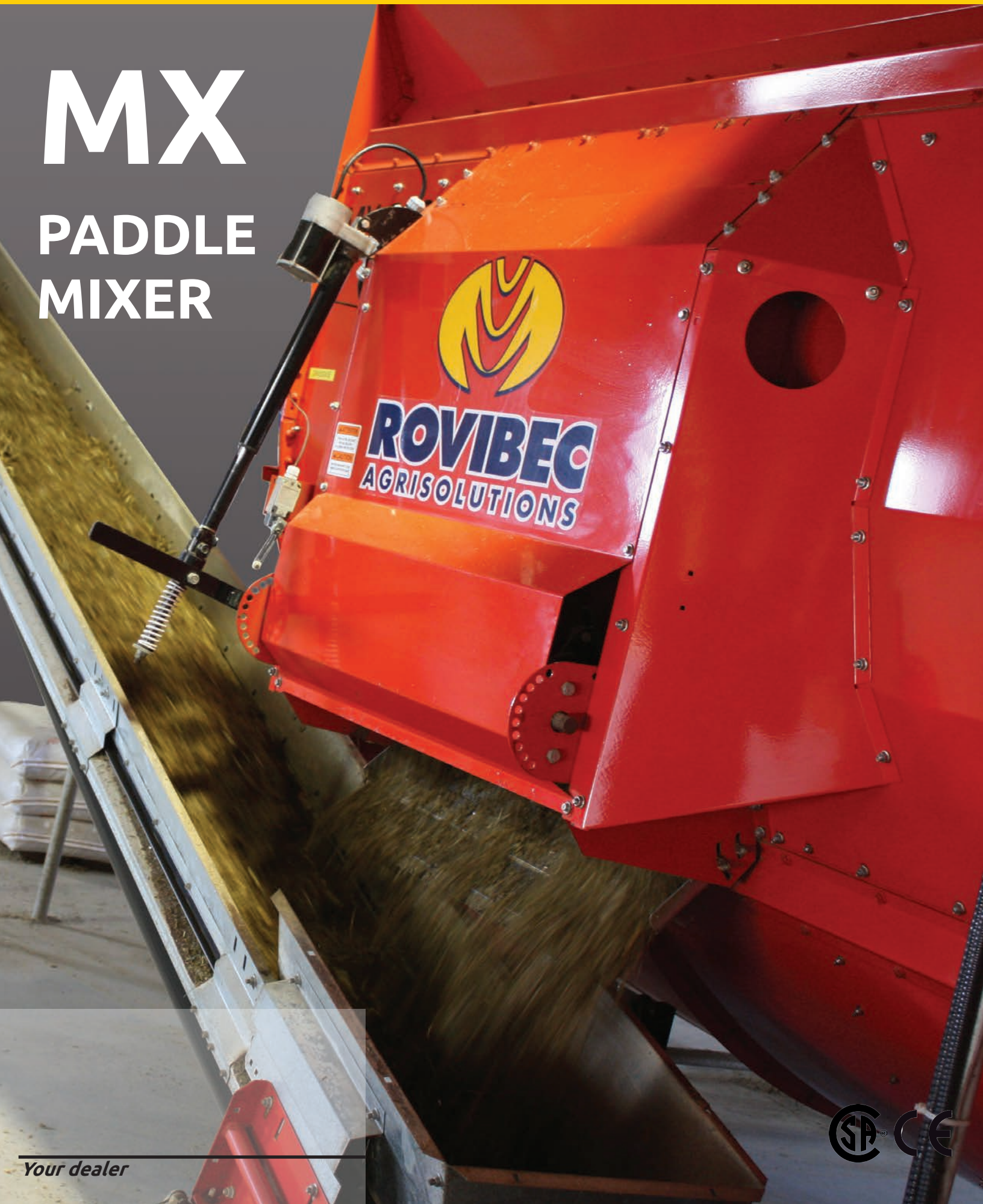

Your dealer



DESCRIPTION

The MX is a **paddle** mixer with specific angular paddle for a high-quality and highly **homogeneous TMR**.

The **unique paddle design** allows you to efficiently mix your recipe while **preserving the fibers**.

Available in several models from **170 to 795 cu.ft.** (4.8 to 22.5 m³), it adapts to your needs!

Its reliability is due to a **simple** though efficient mechanics: and a design aiming at wear resistance for a greater lifespan:

- one chain,
- a sturdy planetary
- two bearings
- oil sump lubrication
- UHMW tub liner with stainless steel fasteners

Very energy efficient, it is a machine that has proven itself for more than 20 years!

DETAILS



PLANETARY AND MOTORIZATION



SIMPLE MECHANICS



TUB - PADDLE & LINER

TECHNICAL SPECIFICATIONS

CAPACITY	Tub from 170 to 795 ft ³ (4,8 to 22.5 m ³)
MOTORIZATION	5 to 10 HP motorization, depending on the model, 240 V, 380V ou 600 V
INCLUSION	DIGI-STAR EZ2500V scale, scale support and arm, loadcells and rubber on all paddle
AVAILABLE OPTIONS	<ul style="list-style-type: none"> ■ Electric actuator ■ Discharge with magnet ■ Reverse discharge ■ Knives

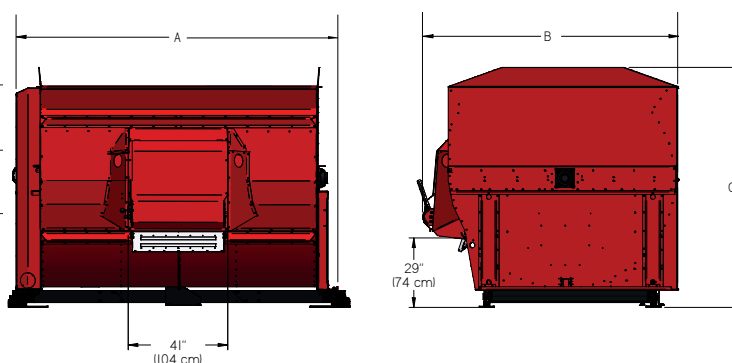

MODEL	LENGHT A		WIDTH B		HEIGHT C		TUB CAPACITY		MIXING CAPACITY**		MOTORI-ZATION	WEIGHT W/O OPTIONS	
	IN	CM	IN	CM	IN	CM	FT3	M3	FT3	M3	HP	LBS	KG
660	94	238,8	92	233,7	87	221	170	4,8	150	4,2	5	3 377	1 532
860	112	284,5	92	233,7	87	221	265	7,5	200	5,7	5	4 620	2 096
1060	135	342,9	92	233,7	87	221	332	9,4	270	7,6	5	6 050	2 744
880	112	284,5	110	279,4	100	254	355	10,1	300	8,5	5	5 225	2 370
1080	135	342,9	110	279,4	100	254	442	12,5	385	10,9	7,5	6 600	2 994
1280	157	398,8	110	279,4	100	254	530	15	450	12,7	7,5	7 700	3 493
1480	187	475	110	279,4	100	254	618	17,5	525	14,9	10	8 855	4 017
1880	231	586,7	110	279,4	100	254	795	22,5	675	19,1	10	11 495	5 214

*Mixing capacity approximately corresponds to 80% tub capacity. Humidity rate influence volume, it is important to respect the maximum recommended weight.